

[BPJ] Audi 2.0 Tfsi 125 Kw Bosch Motronic Med 9.1 MY2004

INFO: -ECU AJ-500 ver. A
 -REDUCER 1.0 Bar
 -INJECTORS HANA 1.9 (Nozzles with one stripe),
Check the gas map

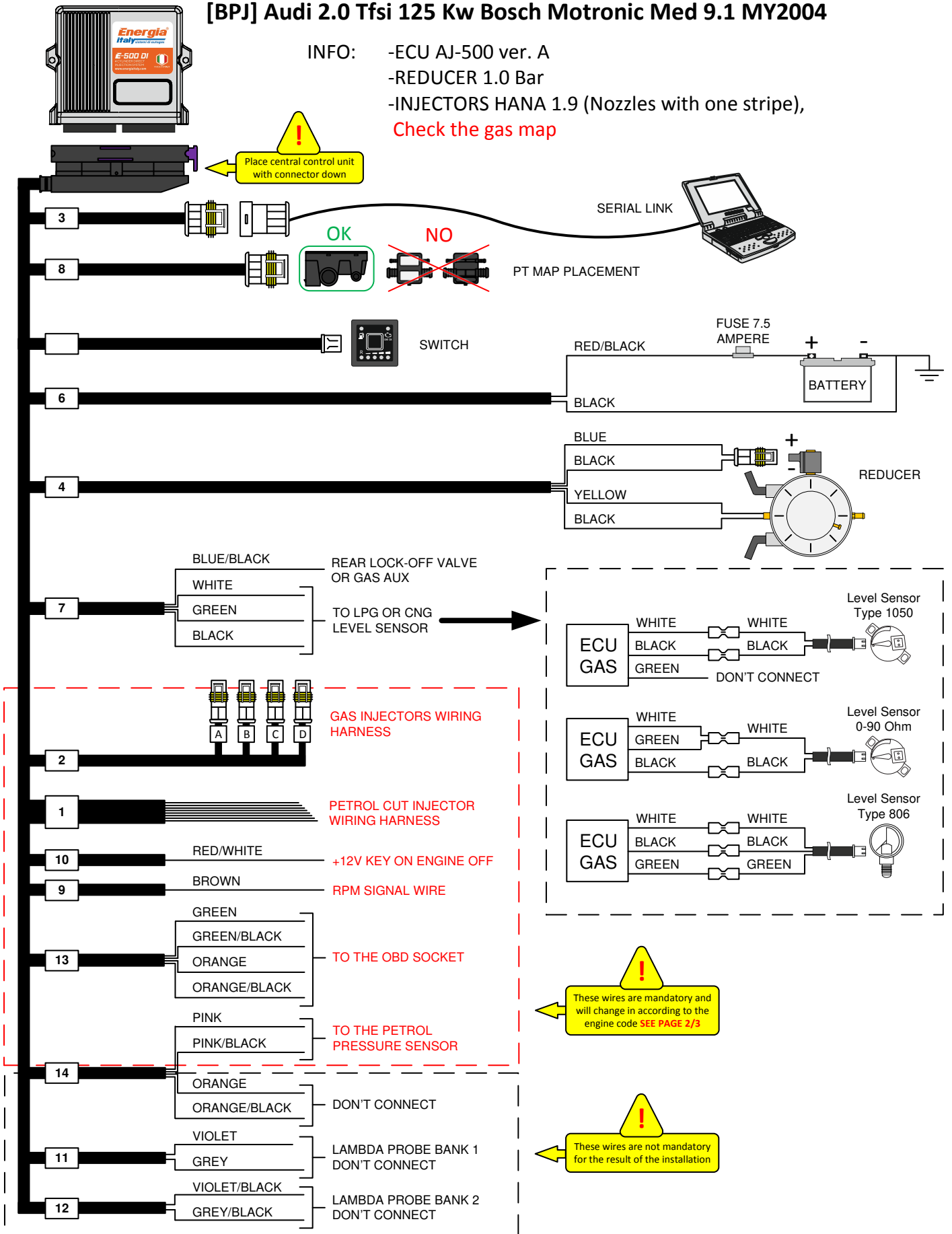

[BPJ] Audi 2.0 Tfsi 125 Kw Bosch Motronic Med 9.1 MY2004

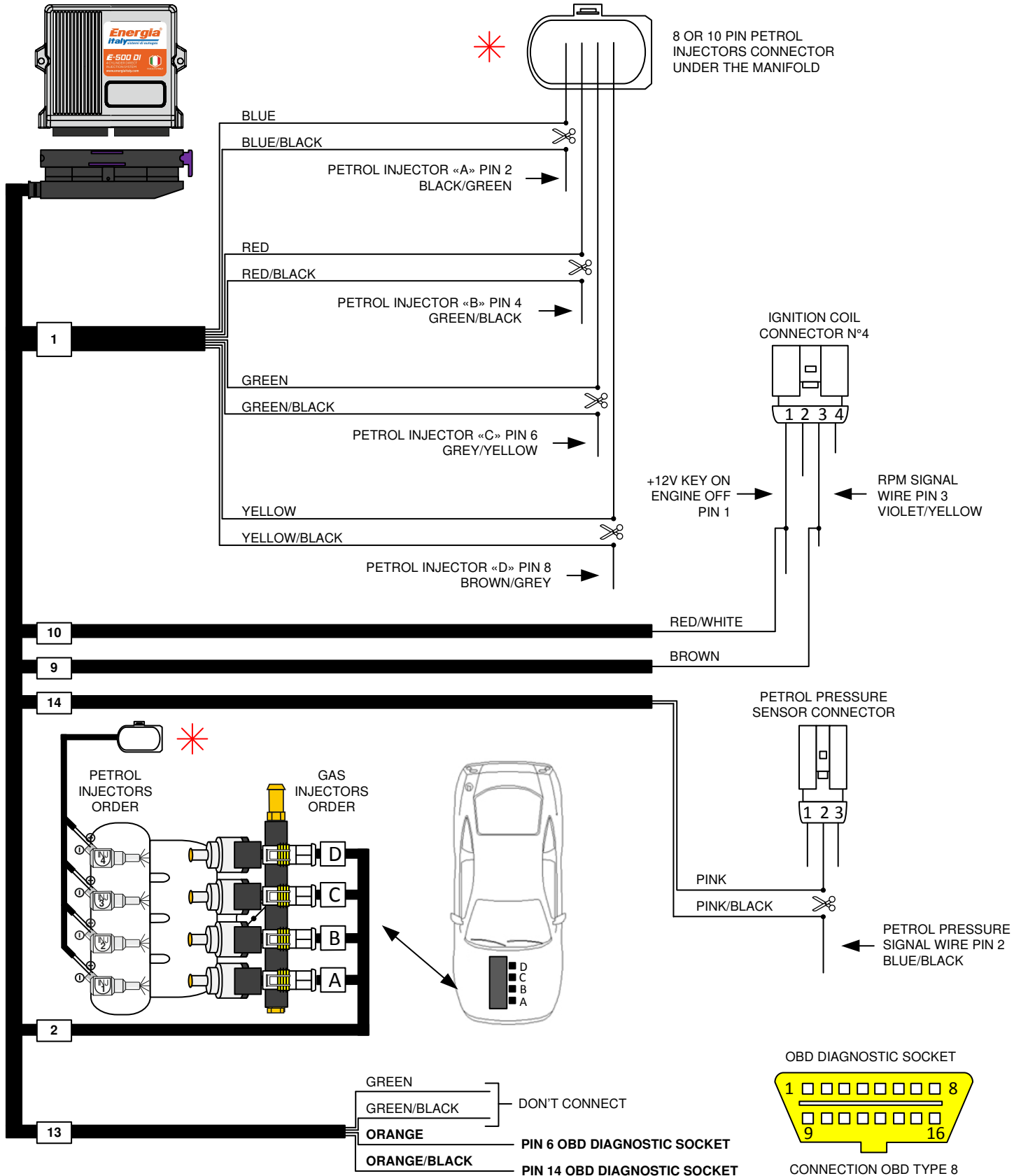

[BPJ] Audi 2.0 Tfsi 125 Kw Bosch Motronic Med 9.1 MY2004

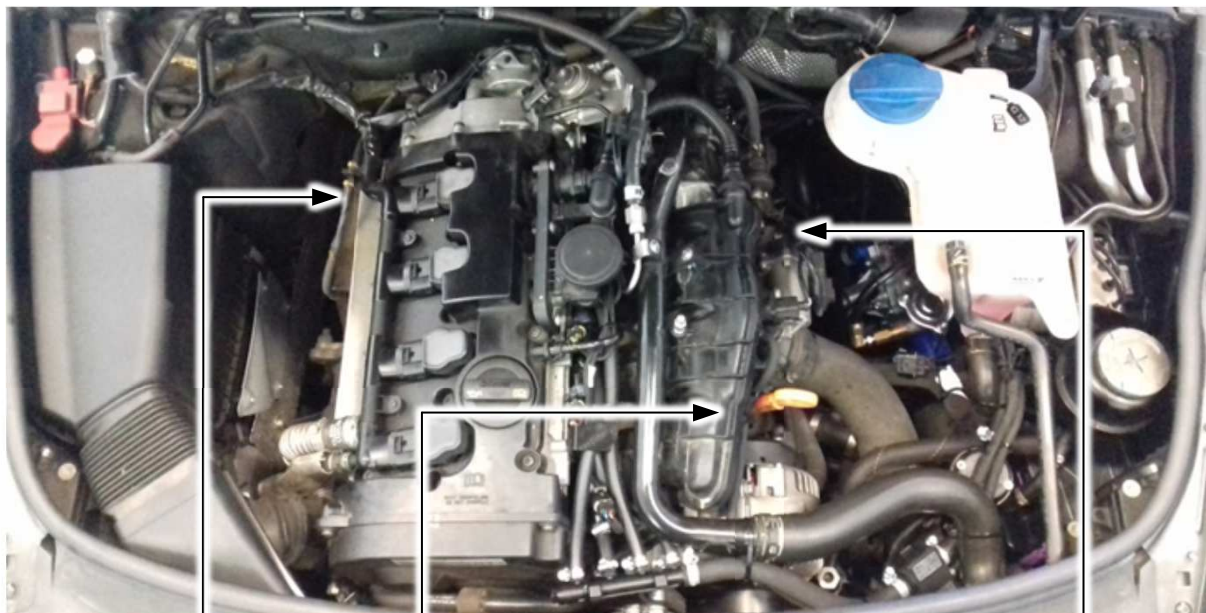

IGNITION COIL
CONNECTOR N°4

PETROL PRESSURE
SENSOR CONNECTOR

8 (OR 10) PIN
CONNECTOR POSITION



8 (OR 10) PIN PETROL
INJECTORS CONNECTOR



MANIFOLD APPLICATION

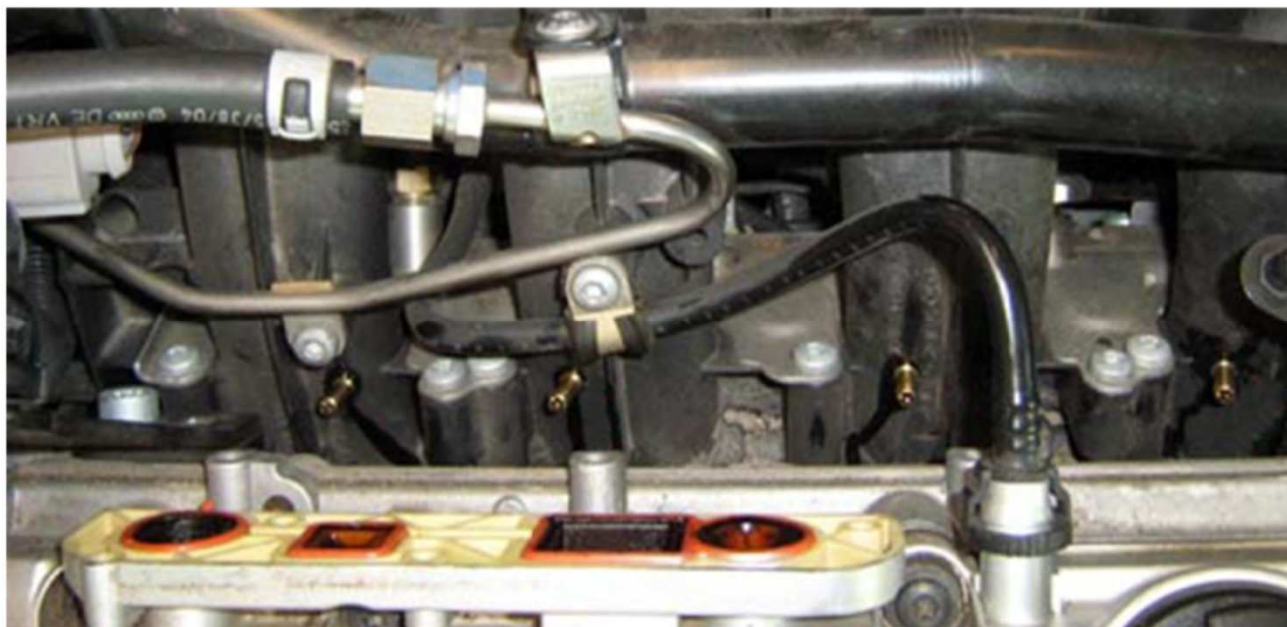

[BPJ] Audi 2.0 Tfsi 125 Kw Bosch Motronic Med 9.1 MY2004

INFO: -ECU AJ-500 ver. A
 -RIDUTTORE 1.0 Bar
 -INIETTORI HANA 1.9 (Ugelli con una tacca),
Controllare la mappa gas

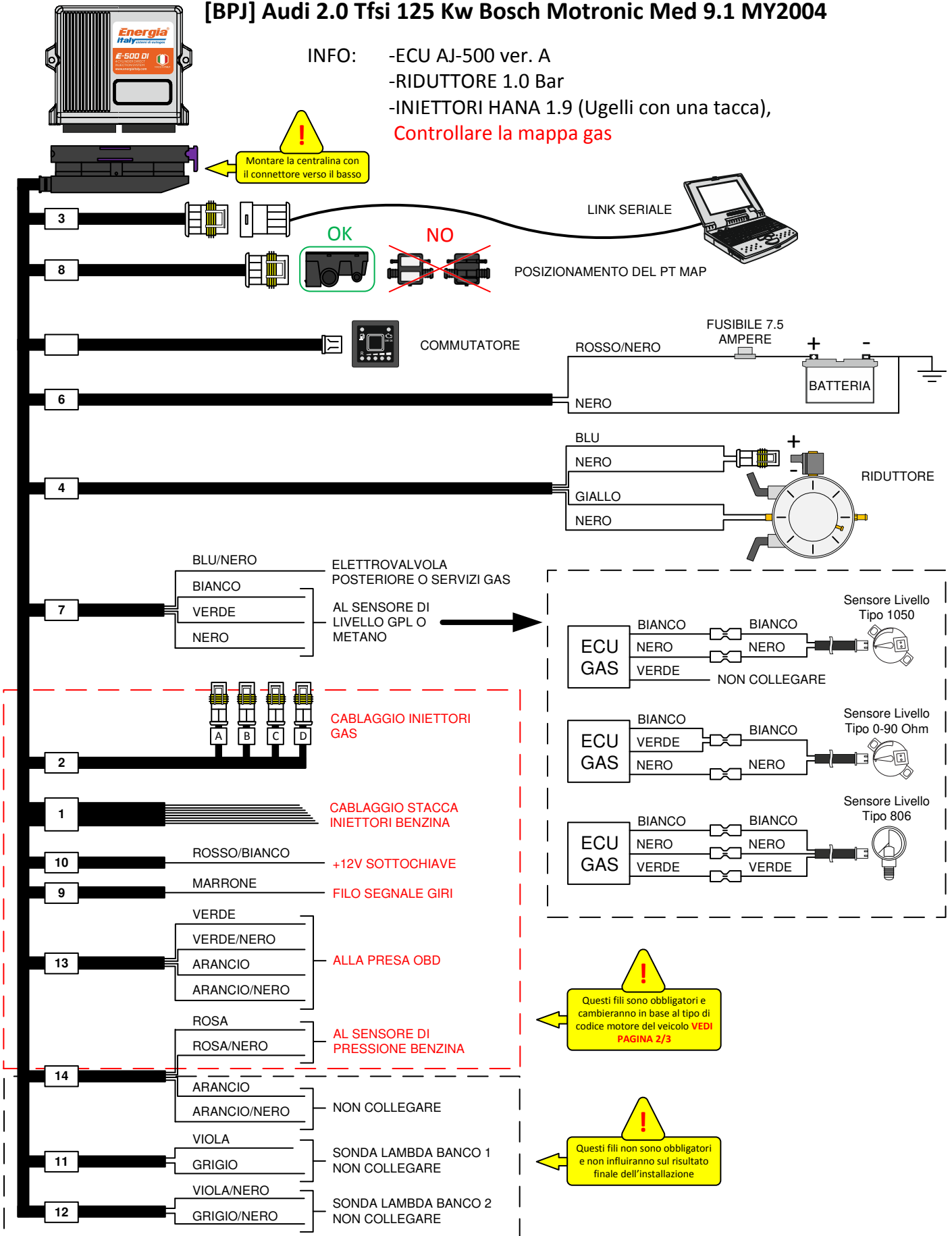

[BPJ] Audi 2.0 Tfsi 125 Kw Bosch Motronic Med 9.1 MY2004

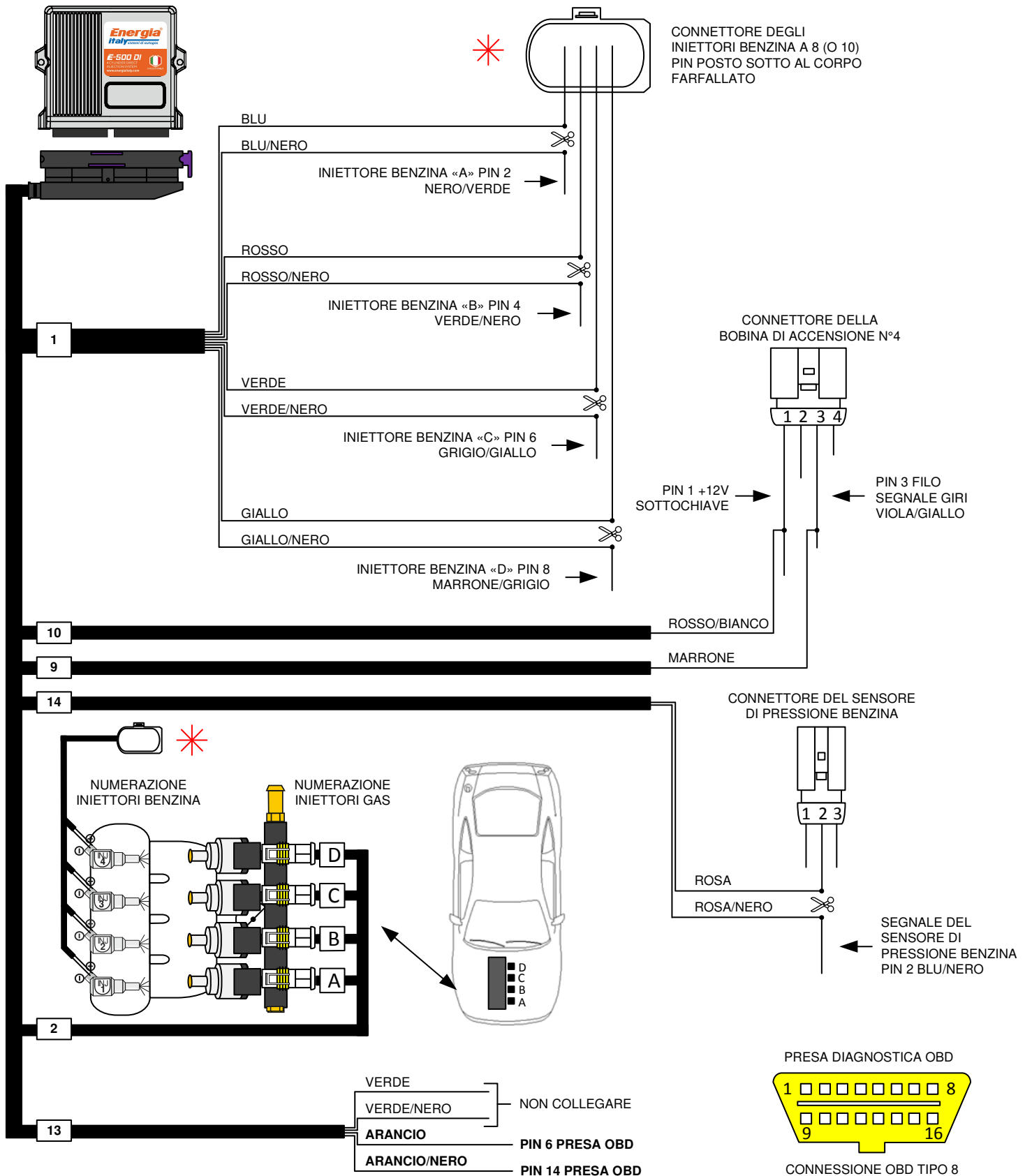

[BPJ] Audi 2.0 Tfsi 125 Kw Bosch Motronic Med 9.1 MY2004

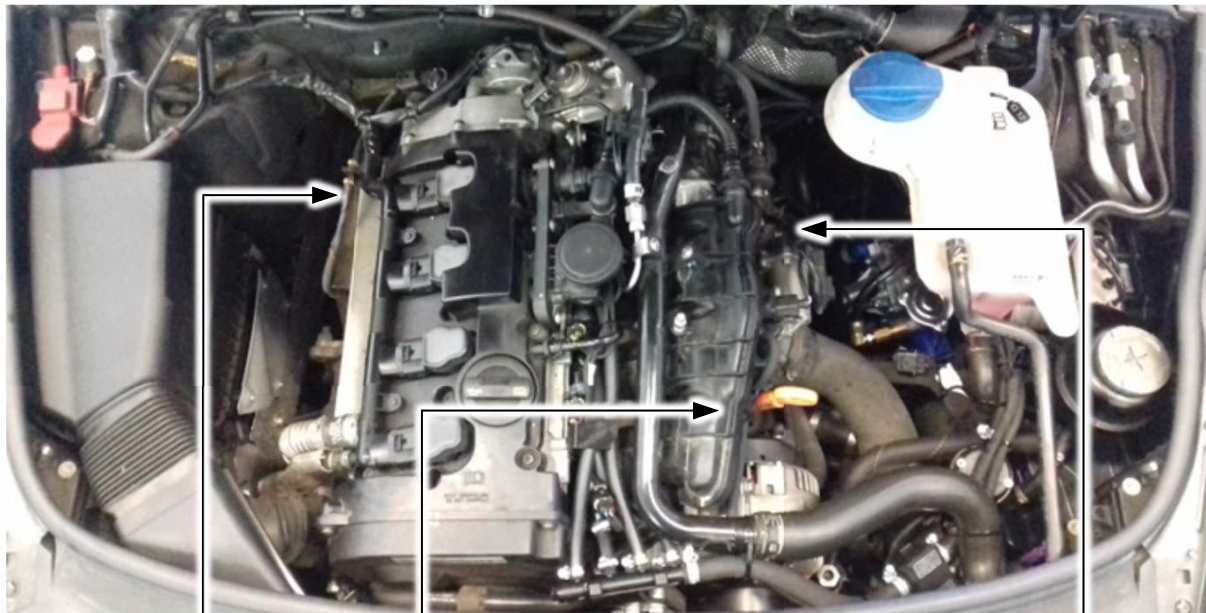

BOBINA D'ACCENSIONE N°4

SENSORE PRESSIONE
BENZINA

POSIZIONE DEL CONNETTORE AD
8 (O 10) PIN



CONNETTORE A 8 (O 10) PIN



APPLICAZIONE SUI COLLETTORI

